

CLEANING TROLLEY

Technical Information

Fully equipped. No extra cleaning supplies need to be purchased. Equipped with various cleaning supplies to facilitate many kinds of cleaning function. Cart type with the maximum load capacity of 150kg is selected. It is equipped with environmental protection wheels which achieve high practicality and flexibility. It has also a braking device that makes the cleaning cart easy to use and safely to operate.

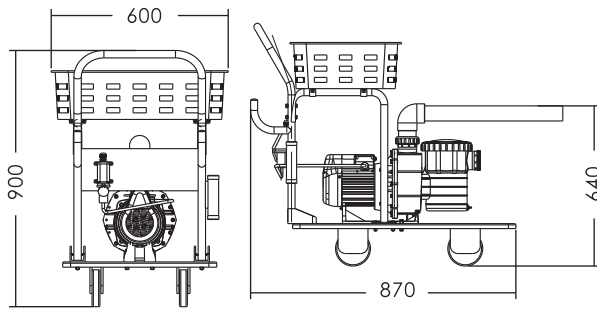

Code	Model No	Pump Voltage	Pump Horsepower	Connection Pipe Size
88050730	CE601	220V / 50-60Hz	2.0hp	2"(63mm)

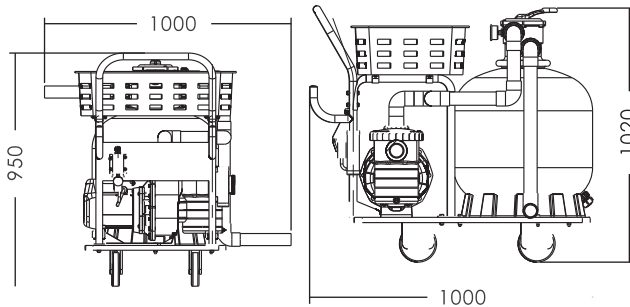

Code	Model No	Pump Voltage	Pump Horsepower	Connection Pipe Size
88050731	CE602	220V / 50-60Hz	2.0hp	1.5"(50mm)

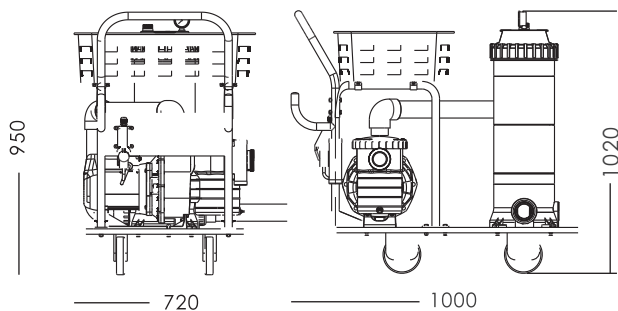

Code	Model No	Pump Voltage	Pump Horsepower	Connection Pipe Size
88050732	CE603	220V / 50-60Hz	2.0hp	2"(63mm)

CE601

- SB20 SB Pump 2.0hp, 220V/50-60Hz, Single Phase
- CE029 Test kit for pH & Chlorine
- CE101 Hand Skimmer & Leaf Rake
- CE102 Standard Hand Skimmer
- CE133 2 x 3m Aluminium Telescopic Pole
- CE163 Premium Grade Vacuum Hose, 38mm x 45ft
- CE201A 18" Plastic Brush
- CE301A 14" Flexible Pool Vacuum
- CE401 Floating Thermometer

CE602

- V500 21" Top Mount Filter, 1.5" Valve
- SB20 SB Pump 2.0hp, 220V/50-60Hz, Single Phase
- CE029 Test kit for pH & Chlorine
- CE101 Hand Skimmer & Leaf Rake
- CE102 Standard Hand Skimmer
- CE133 2 x 3m Aluminium Telescopic Pole
- CE163 Premium Grade Vacuum Hose, 38mm x 45ft
- CE201A 18" Plastic Brush
- CE301A 14" Flexible Pool Vacuum
- CE401 Floating Thermometer

CE603

- CF75 75ft2 Cartridge Filter with 2" union sets
- SB20 SB Pump 2.0hp, 220V/50-60Hz, Single Phase
- CE029 Test kit for pH & Chlorine
- CE101 Hand Skimmer & Leaf Rake
- CE102 Standard Hand Skimmer
- CE133 2 x 3m Aluminium Telescopic Pole
- CE163 Premium Grade Vacuum Hose, 38mm x 45ft
- CE201A 18" Plastic Brush
- CE301A 14" Flexible Pool Vacuum
- CE401 Floating Thermometer