

## FILTER SYSTEM

# FSC SERIES FILTER SYSTEM

### Features

- 1 Easy setup and operate
- 2 UV resistant cartridge filter tank
- 3 Heavy duty ring-lock lid allows easy-open for cleaning and replacing cartridge element
- 4 Oil filled pressure gauge for easy inspection of the operation pressure
- 5 Attached with circulation pump which IPX5 Waterproof standard certified and built-in thermal protection
- 6 Application to domestic swimming pool & spa

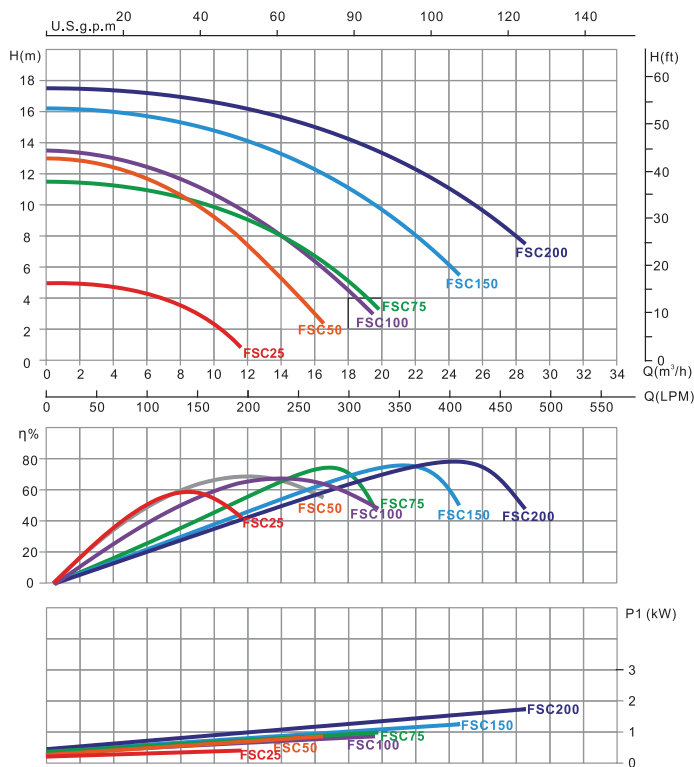

### Highlight Features:

- Maximum Working Pressure 250kPa / 36psi / 2.5bar
- Maximum Water Temperature 40°C(104°F)

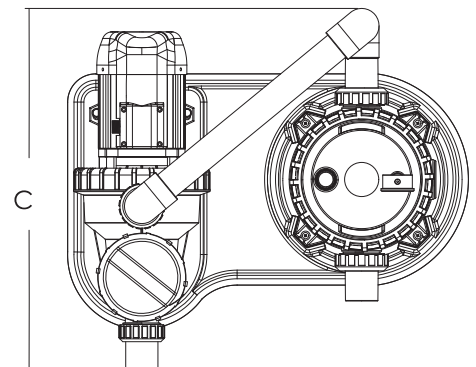

### Technical Information

Code	Model No	Cartridge Filters	Pump	Valve Connections
88340109	FSC025	CF25	SS033	1.5 inch 50mm
88340212	FSC050	CF50	SS100	1.5 inch 50mm
88340324	FSC075	CF75	SC100	1.5 inch 50mm
88340429	FSC100	CF100	SB10	2.0 inch 63mm
88340540	FSC150	CF150	SB15	2.0 inch 63mm
88340631	FSC200	CF200	SB20	2.0 inch 63mm

### Product Dimension

Model No	A mm	B mm	C mm	Max Flow Rate
FSC025	705	580	490	92lpm 5.5m³/h
FSC050	705	760	490	190lpm 11.4m³/h
FSC075	705	940	532	283lpm 17.0m³/h
FSC100	705	1120	600	382lpm 22.9m³/h
FSC150	705	1300	600	555lpm 33.4m³/h
FSC200	705	1480	600	680lpm 40.9m³/h

