

MAINTENANCE OF THE LIGHTS

- 1) Do not leave the lights "on" above water for longer than 1 minute.
- 2) Before switching on the lights, check whether the lights are fully submerged underwater and the circuit boxes are running properly.
- 3) This unit does not need any kind of maintenance. If it is not working properly, please contact EMAUX authorized dealer where you purchase the unit from.
- 4) Warranty will be voided if the Emaux Underwater Light was dismantled by unauthorized personnel.

REPLACEMENT PARTS

Item	Part No.	Description English	QTY
1	03011321	M5*20 Screw (316#)	1
2	01040205	Transparent Face Plate	1
3	01051256	Face Plate	1
4	04011153	Ultra-Thin 252 LED panel 20W, Warm white	1
	04011151	Ultra-Thin 252 LED panel 20W, Cool white	
	04011152	Ultra-Thin 252 LED panel 20W, RGB	
	04011150	Ultra-Thin 252 LED panel 20W, Single Blue	
	04011107	Ultra-Thin 441 LED panel 35W, Warm white	
	04011105	Ultra-Thin 441 LED panel 35W, Cool white	
	04011106	Ultra-Thin 441 LED panel 35W, RGB	
	04011104	Ultra-Thin 441 LED panel 35W, Single Blue	
	04011181	Ultra-Thin 531 LED panel 50W, Warm white	
	04011179	Ultra-Thin 531 LED panel 50W, Cool white	
	04011180	Ultra-Thin 531 LED panel 50W, RGB	
	04011178	Ultra-Thin 531 LED panel 50W, Single Blue	
5	03011360	M3*5 Round head screw	2
6	02021085	Silica gel ring	1
7	01050105	Bottom cover	1
8	03011361	M4*10 Round head self-tapping screw	5
9	02010285	NBR ring	2
10	04013004	2*1.5mm ² *2.5m(D8) Cable	1
11	03012125	M4*10 Flat head self-tapping screw	2
12	01050100	Cable Clip	3
13	01110028	Fastener	4
14	03011364	M4*12 Flat head self-tapping screw	4
15	89044501	Fitting for Concrete Pool	1
16	89045517	Fitting for Vinyl Pool	1

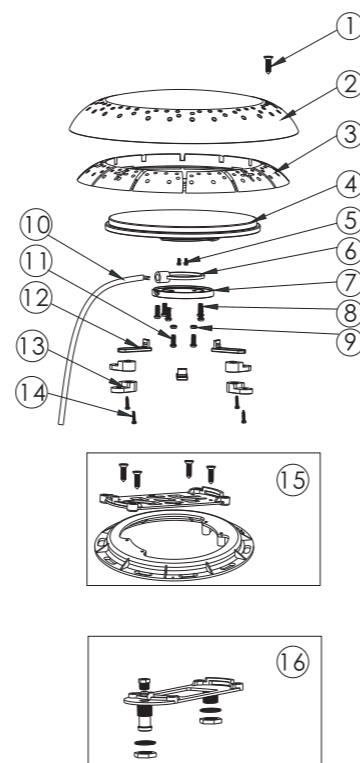

www.emauxgroup.com

E-Lumen

UNDERWATER LIGHT OPERATING MANUAL

Model: E-Lumen-252 / E-Lumen-441 / E-Lumen-531

Keep this manual for future reference

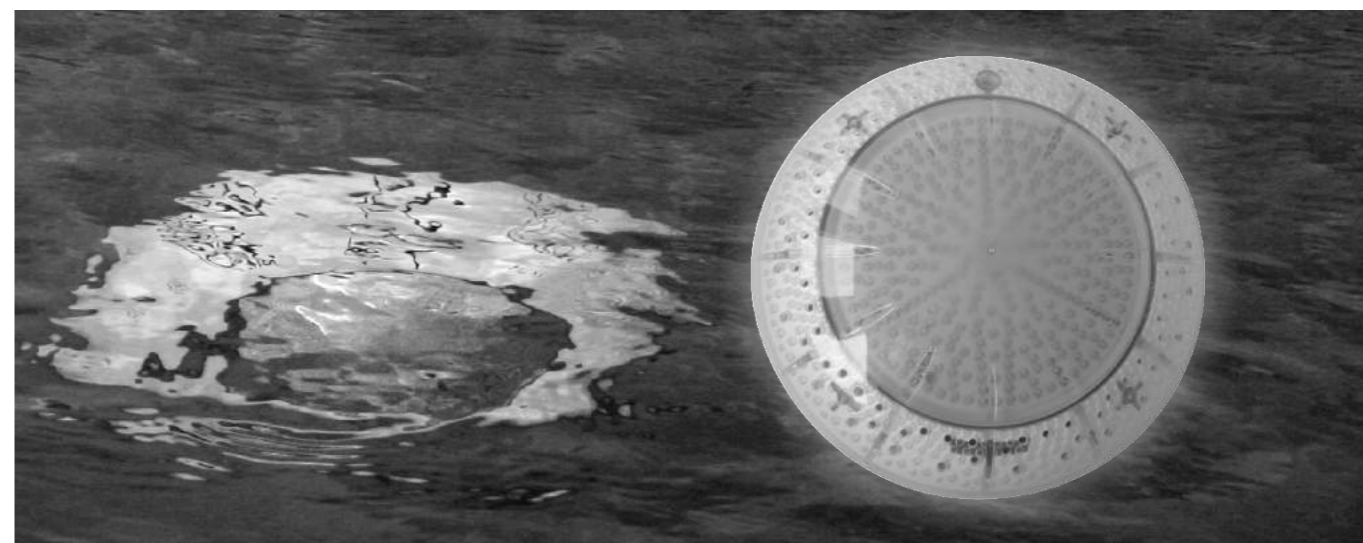

SAFETY WARNINGS

- Only suitably qualified installers are allowed to carry out the installation of this product.
- Avoid direct contact with electrical power.
- Respect all regulations in effect for preventing accidents.
- All units are required to be disconnected from the main electricity before any operation of maintenance.
- Never handle with wet hands and feet.
- This unit is designed for use only when fully submerged in water, connecting with a safety transformer.
- Never operate this Underwater Light for more than 1 minute unless it is totally submerged in water.
- Be sure power is off before installing or removing LED plate. Allow LED plate to cool before replacing.
- This product should be installed according to your local electrical installation ordinances and regulations.
- Maximum Depth for Light installation at 1 meter.
- Maximum Water Temperature Range for light operation 0 - 30°C
- for type Z attachments
The external flexible cable or cord of this luminaire cannot be replaced; if the cord is damaged, the luminaire shall be destroyed.

SPECIFICATION

- A) Electrical Specification : 1) Voltage : AC12V 2) Frequency : 50/60Hz 3) Power : 20W/35W/50W
 B) Colour change options (For RGB version only)

1	White	2	Green
3	Blue	4	Green+Blue
5	Red+Green	6	Red+Blue
7	Mode A: Blue+ Gradual Red	8	Mode B: Green+Gradual Red
9	Mode C: Blue+Gradual Green	10	Mode D: Blue+Gradual Red
11	Mode E: RGB Colour Sequence: Red>Green>Blue	12	Auto Colour Change
13	Mode F: Four Colour Sequence: Red>Green>Blue>Purple	14	Rapid Auto Colour Change

C) Control

- 1) When the light is connected to the transformer directly, the on/off switch controls the colour changes (Associating a light with a transformer and an on/off switch is recommended; If you want all the lights to change colour at the same time, install a master switch, Figure 1).
- 2) If applicable, when the light is connected to the transformer and the transformer to the optional control box, the control panel on the control box and its remote control controls the colour changes (See the Control Box Manual for details).

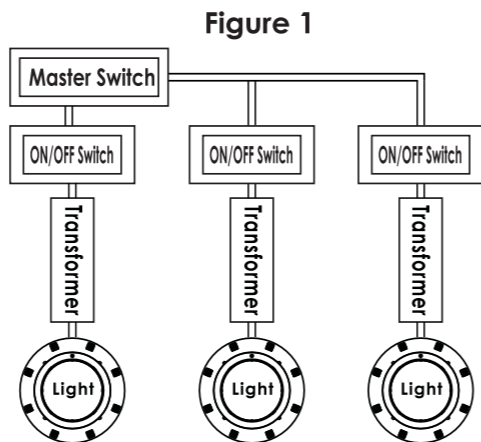

INSTALLATION NOTES

- 1) You should follow the procedures closely when installing the light.
- 2) It is recommended to install a light every 20m², the approximate exposure area of each unit.
- 3) The lights should be installed in the direction that they will not shine directly into the house.
- 4) For training or competition pools, the lights must be installed on the sides in order to prevent swimmers from seeing any glare.
- 5) Nothing should be placed on the poolside directly above the lights for ease of future maintenance.
- 6) If the wires are connected inside the lights, you must seal the connections with leak-proof tapes or products with the same function.
- 7) The cables connecting the lights and the transformers must be at least 6mm² and the distance between them must not exceed 30m (Figure 2); otherwise the lights will not function properly.
- 8) Terminal blocks must meet the IEC60988-2-1 standard having the rated connecting capacity of 4,0mm² use of screw-type terminal at least 25A rated current ,mounted on junction boxes inside. See Figure2-1

Figure 2

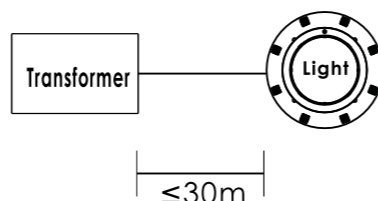
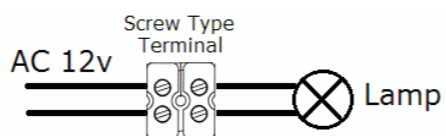

Figure 2-1



INSATALLATION OF THE UNDERWATER LIGHT

A) Light assembly

1. Push light cable through the silicone gel ring and connect wires and tighten screws. (Figure 3)
2. Position the silicone gel ring on the light and place bottom cover and tighten 5 screws. (Figure 4)
3. Place lanolin bottle in boiling water to dissolve to liquid and fill through 2 holes on cover plate (Figure 5)
4. When filled with Lanolin , tighten remaining 2 screws and leave to set whilst installing the retro bracket to the pool wall. When bracket installed fix the pool light to bracket. (Figure 6)

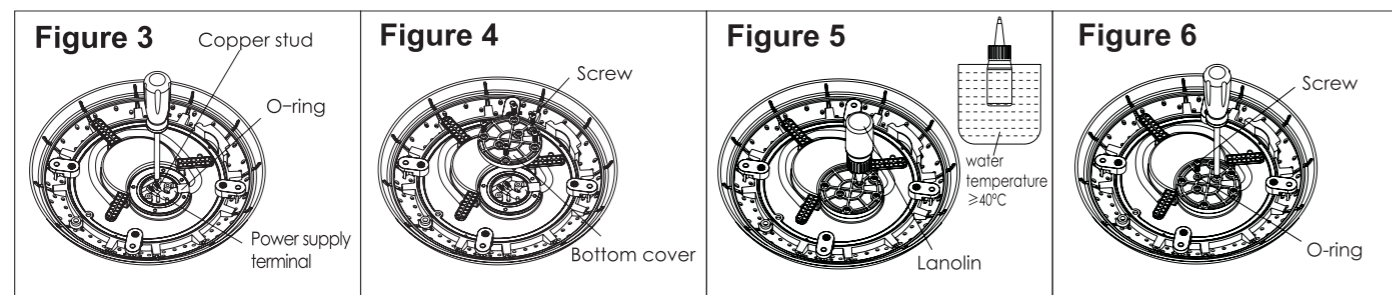

B) Preparing to Install

- 1) The circuit system must comply with local laws and regulations and must be carried out by suitably qualified installers.
- 2) Make sure the voltage is 12V and the terminal box is at least 120cm from the poolside (Figure 7).
- 3) Upon installation, top of the light must be at least 45cm from water surface (Figure 7).

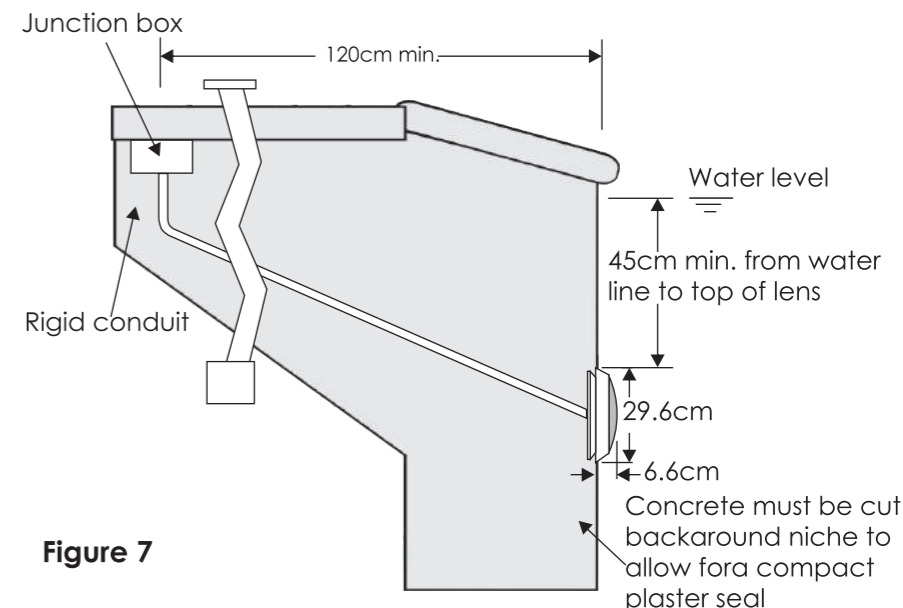
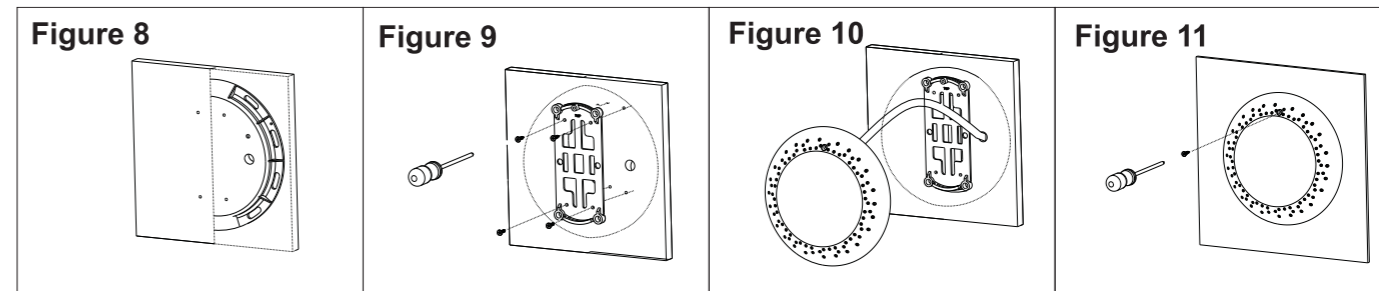

Figure 7

C) Pool Installation

- 1) Embed the Wall Mount into the concrete wall, making sure that it is parallel to the side of the pool.(Figure 8).
- 2) Place the Mounting Plate on the concrete wall and tighten it with 4 screws. The Conduit must be next to the Mounting Plate (Figure 9).
- 3) Note that the light must only be installed on a flat or concave surface.
- 4) Wrap extra cables behind the light to make sure it could be taken to the pool surface for future maintenance (Figure 10).
- 5) Hang the light onto the Mounting Plate and tighten the screws (Figure 11).
- 6) The wire connections inside the terminal box must be sealed by leak-proof tapes to prevent water from leaking into the terminal box through the cables.



D) Fiberglass Pools / Vinyl Pools Installation

- 1) Refer to section "Preparing to Install".
- 2) Make 2 holes on the pool wall (Figure 12).
- 3) Place the o-rings between the Mounting Plate and the pool wall and tighten it with the Nut on the other side of the pool wall (Figure 13).
- 4) Put the cable sequentially through the sealing Nut, the sealing O-ring and the cable hole on the mounting plate; then tighten the Nut (Figure 14).
- 5) Wrap extra cables behind the light to make sure it could be taken to the pool surface for future maintenance. Then, hang the light onto the Mounting Plate and tighten the screws (Figure 15).

